

ZOOMLION

ARTICULATING BOOM LIFTS

ZA10RJE

Comply with CE/ANSI/CSA Standard

HIGHLIGHTS



- ▶ Center layout, great structural rigidity, and small boom deflection
- ▶ Advanced dual control system (valve control + pump control) offers a energy-saving, smooth and efficient control
- ▶ Accurate and efficient AC motor provides strong power and stable control
- ▶ $\pm 90^\circ$ Jib rotation offers great up and over height
- ▶ Compact dimension of 1.2m stowed width, ideal for narrow working conditions
- ▶ Tubular batteries feature long working time and lifespan, and easy for maintenance

FEATURES

Standard Features

Proportional control	Load sensing system
All motion alarm	4.3' LED display
Flashing beacon	Horn
Self-closing entry rod	Timer
Emergency descent system	Jib rotation
Emergency stop button	Vertical lifting function
Auto-leveling system	Thumb joystick for steering
On-board diagnostic system	35A battery smart charger
Over tilt protection system	Electric quantity display
Solid seamless tire	Low electric quantity protection

Accessories & Options

- ▶ Platform light
- ▶ AC power to platform
- ▶ Air line to platform
- ▶ Electric auxiliary pump
- ▶ Platform console cover (Adjust rated capacity to 210kg)
- ▶ Secondary guarding system
- ▶ Low-temperature hydraulic oil
- ▶ Synthetic biodegradable hydraulic oil



ACCESS WITH ZOOMLION GREEN

Phone: 0086(731)-88353680 0086(731)-88250971
E-mail: awm@zoomlion.com

Add: ZOOMLION Wangcheng Industrial Park, Tengfei Road 997, Changsha, Hunan, China
Web: www.en.zoomlion.com

MAIN SPECS OF ARTICULATING BOOM LIFTS

ZA10RJE

Comply with CE/ANSI/CSA Standard

Model	ZA10RJE	
	Imperial	Metric
Dimension		
Work Height	37ft 11in	11.55m
Platform Height	31ft 4in	9.55m
Horizontal Outreach	22ft 5in	6.85m
Up and Over Height	15ft 1in	4.6m
A - Stowed Length	18ft 1in	5.5m
B - Stowed Width	3ft 11in	1.19m
C - Stowed Height	6ft 6in	1.98m
D - Platform Length	3ft 10in	1.17m
E - Platform Width	2ft 6in	0.76m
Jib length	4ft 1in	1.24m
F - Wheelbase	5ft 5in	1.65m
G - Ground Clearance	4in	0.1m
I - Transport Length (Jib tucked under)	13ft	3.95m
J - Transport Height (Jib tucked under)	8ft	2.45m
Performance		
Platform Capacity	510lbs	230kg
Drive Speed	3.11mph	5km/h
Gradeability	35% (19°)	35% (19°)
Turning Radius (Inside)	5ft 7in	1.7m
Turning Radius (Outside)	10ft 8in	3.25m
Turntable Swing	355° non-continuous	
Jib Swing	±90°	
Platform Rotation	±90°	
H-Tail Swing	0m	
Max. Wind Speed	28mph	12.5m/s
Power		
Battery	24×2V/330Ah	
Charger	48V/35A	
Drive Motor	AC 48V/4.4hp	AC 48V/3.3kW
Lift Motor	DC 48V/6hp	DC 48V/4.5kW
Auxiliary Power	Standard: Manual pump/Option: Electric Pump	
Hydraulic Tank Capacity	3.96(us gal)	15L
Tire		
Type	22X7X17.75 seamless tire	
Weight		
Gross	14440lbs	6550kg

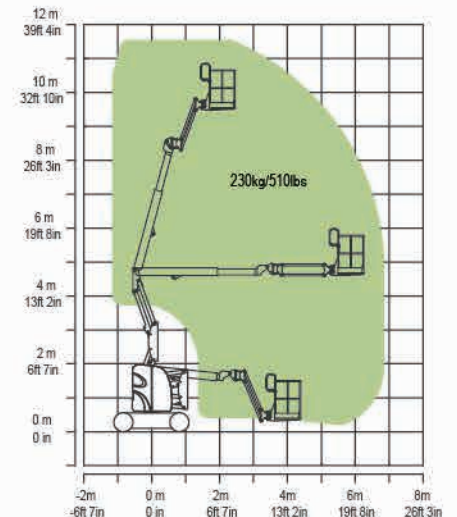
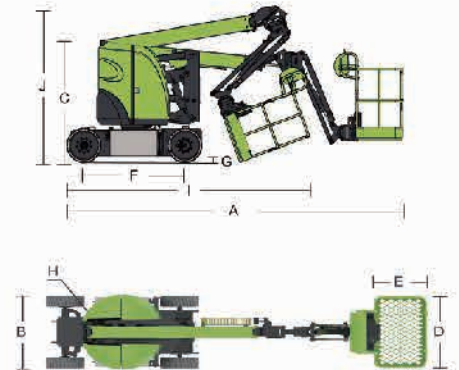

Range of Motion ZA10RJE

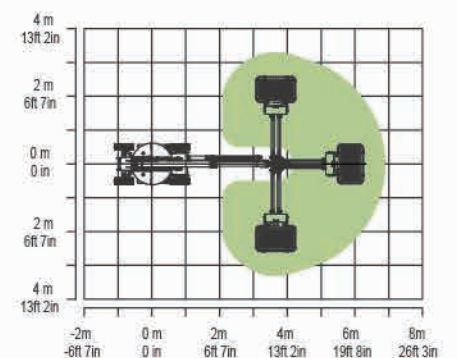

Range of Jib Swing Motion ZA10RJE

ZOOMLION ARTICULATING BOOM LIFTS

ZA14J

Comply with CE/ANSI/CSA Standard

HIGHLIGHTS

- ▶ 300kg/660lb platform capacity for higher efficiency
- ▶ Build-in multiple pressure control leveling system to enhance stability
- ▶ Precise load sensing system to improve overload safety operations
- ▶ Integrated with rotary reducer to enhance rotation stability
- ▶ Hostile Kits available for dusty working environment
- ▶ Deadweight Lowering System for smooth operation and energy efficiency

FEATURES

Standard Features

Horn
All motion alarm
Proportional control
Self-closing entry gate
Flashing amber beacon
Auto-leveling system
Emergency stop button
Over tilt protection system
Emergency descent system
On-board diagnostic system
Oscillating axle
4.3' LED display
Load sensing system
Swing-out engine tray
Secondary Guarding System

Accessories & Options

- ▶ Platform work lights
- ▶ AC power to platform
- ▶ Air line to platform
- ▶ Engine heater
- ▶ Low-temperature hydraulic oil
- ▶ Non-marking tire

ACCESS WITH ZOOMLION GREEN

Phone: 0086(731)-88353680-0086(731)-88250971
E-mail: awm@zoomlion.com

Add: ZOOMLION Wangcheng Industrial Park, Tengfei Road 997, Changsha, Hunan, China
Web: www.en.zoomlion.com



MAIN SPECS OF ARTICULATING BOOM LIFTS

ZA14J

Comply with CE/ANSI/CSA Standard

Model	ZA14J	
	Imperial	Metric
Size		
Work Height	51ft 10in	15.80m
Platform Height	45ft 3in	13.80m
Horizontal Outreach	27ft 3in	8.30m
Up and Over Height	24ft 9in	7.55m
A - Stowed Length	21ft 7in	6.57m
B - Stowed Width	7ft 7in	2.30m
C - Stowed Height	7ft 5in	2.27m
D - Platform Length	6ft	1.83m
E - Platform Width	2ft 6in	0.76m
Jib Length	4ft 1in	1.24m
F - Wheelbase	7ft 9in	2.36m
G - Ground Clearance	1ft 5in	0.42m
Performance		
Platform Capacity	660 lb	300kg
Drive Speed	4.23 mph	6.8km/h
Gradeability	45%(24°)	45%(24°)
Axles Oscillation	4in	0.1m
Turning Radius (Inside)	6ft 9in	2.06m
Turning Radius (Outside)	15ft 8in	4.78m
Swing	355° non-continuous	
Platform Rotation	±90°	
H-Tail Swing	0	
Max. Wind Speed	28mph	12.5m/s
Power		
Diesel Engine	Kubota V2403 36kW/2600rpm Weichai WP3.2G50E317A 36.8kW/2500rpm Deutz D2.9 L4 36.4kW/2600rpm	
Fuel Tank Capacity	17.2 (us gal)	65L
Auxiliary Power	12V	
Control Voltage	12V	
Hydraulic System Capacity	39.6 (us gal)	150L
Hydraulic Tank Capacity	20.1 (us gal)	76L
Drive	4WD	
Tire		
Type	315/55 D20 Foam-filled Tires 33×12-20 Solid Tires	
Weight		
Gross	15653 lb	7100kg

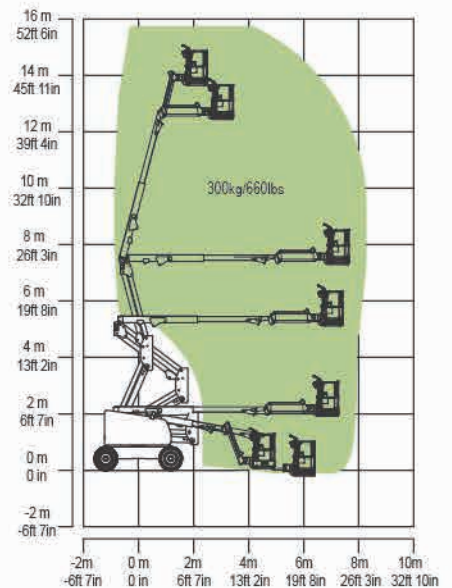
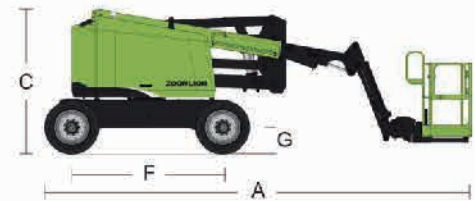

Range of Motion ZA14J

ZOOMLION

ELECTRIC ARTICULATING BOOM LIFT

Comply with CE/ANSI/CSA Standard

HIGHLIGHTS

- ▶ Center layout, great structural rigidity, and small boom deflection
- ▶ Advanced dual control system (valve control + pump control) offers a energy-saving, smooth and efficient control
- ▶ Accurate and efficient traveling AC drive system provides strong power and stable control
- ▶ Large capacity tube battery + fast charger for longer battery life of 5 years and working time, the charging time is less than 8 hours.
- ▶ Customized lithium-ion battery features longer running time and lifespan, maintenance-free and long-term warranty.
- ▶ Only model with standard 360° continuous rotation in the same meter class features higher work efficiency.
- ▶ Industry's first battery health management system protects the battery and prolongs its life. Protected by national patents.

FEATURES

Standard Features

- | | |
|--------------------------|-----------------------------|
| Proportional control | On-board diagnostic system |
| All motion alarm | Over tilt protection system |
| Flashing amber beacon | Oscillating axle |
| Self-closing entry gate | Load sensing system |
| Emergency descent system | 4.3' LED display |
| Emergency stop button | Horn |
| Auto-leveling system | Secondary Guarding System |

Accessories & Options

- AC power to platform
- Air line to platform
- Non-marking tire
- Low-temperature hydraulic oil

ACCESS WITH ZOOMLION GREEN

Phone: 0086(731)-88353680 0086(731)-88250971
E-mail: awm@zoomlion.com

Add: ZOOMLION Wangcheng Industrial Park, Tengfei Road 997, Changsha, Hunan, China
Web: www.en.zoomlion.com



ZOOMLION

ELECTRIC ARTICULATING BOOM LIFTS

ZA14JE/ZA14JE-Li

Comply with CE/ANSI/CSA Standard

Model	ZA14JE		ZA14JE-Li	
	Imperial	Metric	Imperial	Metric
Size				
Work Height	52ft 6in	16m	52ft 6in	16m
Platform Height	45ft 11in	14m	45ft 11in	14m
Horizontal Outreach	26ft 7in	8.1m	26ft 7in	8.1m
Up and Over Height	25ft 5in	7.74m	25ft 5in	7.74m
A - Stowed Length	21ft 8in	6.6m	21ft 8in	6.6m
B - Stowed Width	5ft 9in	1.75m	5ft 9in	1.75m
C - Stowed Height	6ft 7in	2m	6ft 7in	2m
D - Platform Length	5ft	1.52m	5ft	1.52m
E - Platform Width	2ft 6in	0.76m	2ft 6in	0.76m
Jib Length	4ft 1in	1.24m	4ft 1in	1.24m
F - Wheelbase	6ft 9in	2.05m	6ft 9in	2.05m
G - Ground Clearance	8in	0.20m	8in	0.20m
Performance				
Platform Capacity	510 lb	230kg	510 lb	230kg
Drive Speed	3.79 mph	6.1km/h	3.36 mph	5.4km/h
Gradeability	30% (17°)		30% (17°)	
Axles Oscillation	/	/	/	/
Turning Radius (Inside)	2ft 7in	0.79m	2ft 7in	0.79m
Turning Radius (Outside)	10ft 4in	3.15m	10ft 4in	3.15m
Swing	360° non-continuous		360° continuous	
Platform Rotation	±90°		±90°	
H-Tail Swing	0in	0m	0in	0m
Max. Wind Speed	28mph	12.5m/s	28mph	12.5m/s
Power				
Battery	48V/320Ah		48V/315Ah Li-ion	
Charger	48V/35A		48V/60A	
Drive Motor	AC 32V/4.4hp	AC 32V/3.3kW	AC 32V/4.4hp	AC 32V/3.3kW
Lift Motor	DC 48V/6.7hp	DC 48V/5kW	DC 48V/6.7hp	DC 48V/5kW
Auxiliary Power	Manual Pump		Manual Pump	
Hydraulic Tank Capacity	7.9 (us gal)	30L	7.9 (us gal)	30L
Drive	2WD		2WD	
Tire				
Type	240/55D17.5 Foam-filled Tires 250/15 Solid Tires		240/55D17.5 Foam-filled Tires 250/15 Solid Tires	
Weight				
Gross	14991 lb	6800kg	14991 lb	6800kg

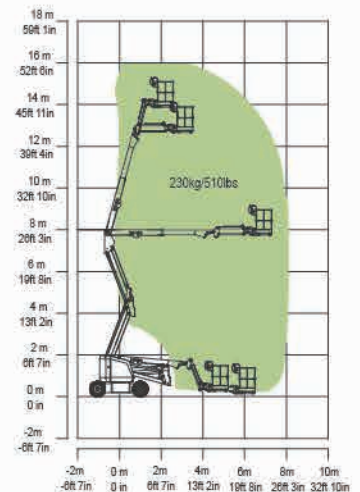

Range of Motion ZA14JE

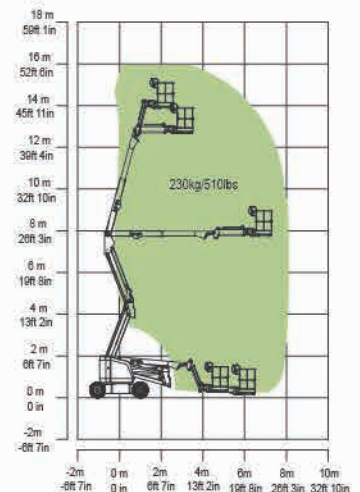

Range of Motion ZA14JE-Li

ZOOMLION

NEW ROUGH TERRAIN ELECTRIC ARTICULATING BOOM LIFT

ZA16JERT/ZA16JERT-Li

Comply with CE/ANSI Standard

HIGHLIGHTS

- ▶ Center layout, great structural rigidity, and small boom deflection
- ▶ Accurate and efficient traveling AC drive system provides strong power and stable control, motor maintenance-free
- ▶ First electrical off-road articulating boom lift of 16m height with strong power suits for complicated working conditions
- ▶ First electrical off-road articulating boom lift of 16m height with strong power suits for complicated working conditions (ZA16JERT Only)
- ▶ 4WD provides strong power, ideal for off-road application (ZA16JERT-Li Only)
- ▶ Advanced dual control system (valve control + pump control) offers a energy-saving, smooth and efficient control (ZA16JERT-Li Only)
- ▶ Large-capacity lithium battery features long-lasting battery life, and number of charge and discharge cycles reaches 2500 times, the whole life cycle is maintenance-free, and a 5-year warranty is provided control (ZA16JERT-Li Only)

FEATURES

Standard Features

- Proportional control
- All motion alarm
- Flashing beacon
- Self-closing entry gate
- Emergency descent system
- Emergency stop button
- Auto-leveling system
- On-board diagnostic system
- Over tilt protection system
- Load sensing system
- 4.3" LED display
- Horn
- Secondary guarding system

Accessories & Options

- AC power to platform
- Air line to platform
- Non-marking tire
- Platform work lights
- Low-temperature Hydraulic Oil

ACCESS WITH ZOOMLION GREEN

Phone: 0086(731)-88253680 0086(731)-88250971
E-mail: awr@zoomlion.com

Add: ZOOMLION Wangcheng Industrial Park, Fanglei Road 997, Changsha, Hunan, China
Web: www.es.zoomlion.com

ZOOMLION

ROUGH TERRAIN ELECTRIC ARTICULATING BOOM LIFT

NEW ROUGH TERRAIN

ZA16JERT/ZA16JERT-Li Comply with CE/ANSI Standard

Model	ZA16JERT		ZA16JERT-Li	
	Imperial	Metric	Imperial	Metric
Size				
Work Height	58ft 5in	17.8m	58ft 5in	17.8m
Platform Height	51ft 10in	15.8m	51ft 10in	15.8m
Horizontal Outreach	31ft 11in	9.72m	31ft 11in	9.72m
Up and Over Height	26ft 3in	8m	26ft 3in	8m
A - Stowed Length	25ft 3in	7.7m	25ft 3in	7.7m
B - Stowed Width	7ft 6in	2.3m	7ft 6in	2.3m
C - Stowed Height	7ft 4in	2.23m	7ft 4in	2.23m
D - Platform Length	6ft	1.83m	5ft	1.52m
E - Platform Width	2ft 6in	0.76m	2ft 6in	0.76m
F - Wheelbase	7ft 9in	2.36m	7ft 9in	2.36m
G - Ground Clearance	1ft 2in	0.36m	1ft 2in	0.36m
Performance				
Platform Capacity	550 lb	250kg	550 lb	250kg
Drive Speed	3.79 mph	6.1km/h	3.4 mph	5.4 km/h
Gradeability	45%(24°)		45%(24°)	
Axles Oscillation	8in	0.20m	8in	0.20m
Turning Radius (Inside)	6ft 9in	2.06m	6ft 9in	2.06m
Turning Radius (Outside)	15ft 8in	4.78m	15ft 8in	4.78m
Turntable Swing	360° non-continuous		360° non-continuous	
Platform Rotation	±90°		±90°	
H-Tail Swing	8in	0.2m	0.6ft	0.2m
Max. Wind Speed	27.96mph	12.5m/s	27.96mph	12.5m/s
Power				
Battery	24×2V/320Ah		48V/315Ah Li-ion battery	
Charger	48V/35A		48V/60A	
Drive Motor	AC 32V		AC 32V	
Lift Motor	AC 32V		AC 32V	
Auxiliary Power	12V DC Electrical pump		12V DC Electrical pump	
Hydraulic Tank Capacity	7.9 (us gal)	30L	7.9 (us gal)	30L
Tire				
Type	33×12 Foam-filled tire		33×12 Foam-filled tire	
Weight				
Gross	16093 lb	7300 kg	16093lb	7300kg

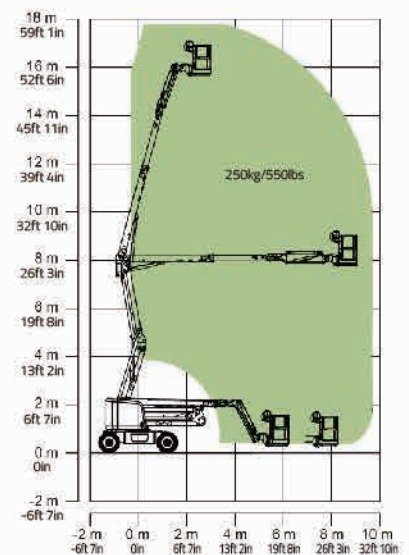
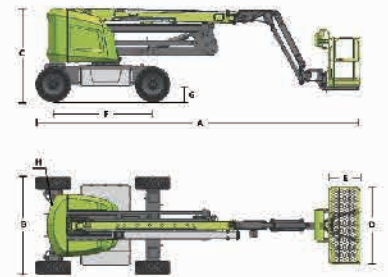

Range of Motion ZA16JERT/ZA16JERT-Li

ZOOMLION ACCESS reserves the right to make specification and/or equipment changes without prior notification. Product specifications are updated to August, 2022.

ZOOMLION

ELECTRIC ARTICULATING BOOM LIFT ZA20JE/ZA20JERT-Li

Comply with CE/ANSI/CSA Standard

HIGHLIGHTS

- ▶ Fast lift system directly lowers the boom from the highest position to the ground, no need to fold the boom to improve work efficiency.
- ▶ Accurate and efficient traveling AC drive system and on-board motion AC drive system provides strong power, stable control and maintenance-free motor.
- ▶ Independent auxiliary power system for more secure application
- ▶ Provide greater work height of 21.45m and lift capacity of 250kg than competitor (ZA20JE Only)
- ▶ Provide greater work height of 21.38m and lift capacity of 250kg than competitor (ZA20JERT-Li Only)
- ▶ Large reduction ratio reducer provides stronger gradeability (ZA20JERT-Li Only)
- ▶ Large-capacity lithium battery features long-lasting battery life, and number of charge and discharge cycles reaches 2500 times, the whole life cycle is maintenance-free, and a 5-year warranty is provided (ZA20JERT-Li Only)

FEATURES

Standard Features

- | | |
|--------------------------|-----------------------------|
| Proportional control | Emergency stop button |
| All motion alarm | Auto-leveling system |
| Flashing amber beacon | On-board diagnostic system |
| Self-closing entry gate | Over tilt protection system |
| Emergency descent system | Oscillating axle |

- Load sensing system
- 4.3" LED display
- Horn
- Secondary Guarding System

Accessories & Options

- AC power to platform
- Air line to platform
- Non-marking tire
- Low-temperature hydraulic oil

ACCÈS AVEC ZOOMLION VERT

Phone: 0086(731)-88353689 0086(731)-88250971
E-mail: awm@zoomlion.com

Add: ZOOMLION Wangcheng Industrial Park, Tengze Road 997, Changsha, Hunan, China
Web: www.en.zoomlion.com

ZOOMLION

ELECTRIC ARTICULATING BOOM LIFTS

ZA20JE/ZA20JERT-Li

Comply with CE/ANSI/CSA Standard

Model	ZA20JE		ZA20JERT-Li	
	Imperial	Metric	Imperial	Metric
Size				
Work Height	70ft 4in	21.45m	70ft 1in	21.38m
Platform Height	63ft 10in	19.45m	63ft 7in	19.38m
Horizontal Outreach	39ft 6in	12.05m	39ft 8in	12.1m
Up and Over Height	27ft 1in	8.25m	27ft 1in	8.25m
A - Stowed Length	28ft 7in	8.72m	28ft 10in	8.8m
B - Stowed Width	8ft 1in	2.46m	8ft 1in	2.46m
C - Stowed Height	8ft 3in	2.52m	8ft 3in	2.52m
D - Platform Length	6.00ft (standard) 8.01ft (option)	1.83m (standard) 2.44 (option)	6ft (standard) 8ft (option)	1.83m (standard) 2.44 (option)
E - Platform Width	2.49ft (standard) 2.99ft (option)	0.76m (standard) 0.91 (option)	2ft 6in (standard) 3ft(option)	0.76m (standard) 0.91 (option)
F - Wheelbase	8ft 3in	2.52m	8ft 3in	2.52m
G - Ground Clearance	1ft 1in	0.33m	1ft 4in	0.4m
Performance				
Platform Capacity	550 lb	250kg	550 lb	250kg
Drive Speed	3.79 mph	6.1km/h	3.23 mph	5.2km/h
Gradeability	45%(24°)		45%(24°)	
Axles Oscillation	8in	0.20m	8in	0.20m
Turning Radius (Inside)	9ft 1in	2.78m	9ft 1in	2.78m
Turning Radius (Outside)	18ft	5.49m	18ft	5.49m
Swing	360° continuous/400° non-continuous		360° continuous	
Platform Rotation	±90°		±90°	
H-Tail Swing	2ft	0.6m	2ft 1in	0.64m
Max. Wind Speed	28mph	12.5m/s	27.96mph	12.5m/s
Power				
Battery	24×2V/440Ah		48V/315Ah Li-ion battery	
Charger	48V/60A		48V/60A	
Drive Motor	AC 32V/4.4hp	AC 32V/3.3kW	AC 32V	
Lift Motor	AC 32V/13.4hp	AC 32V/10kW	AC 32V	
Auxiliary Power	12V DC		12V DC	
Hydraulic Tank Capacity	19.8 (us gal)	75L	19.8 (us gal)	75L
Drive	4WD		4WD	
Tire				
Type	33×12 D610 Foam-filled Tires		33×12 D610 Foam-filled tire	
Weight				
Gross	20283 lb	9200kg	20392 lb	9250kg

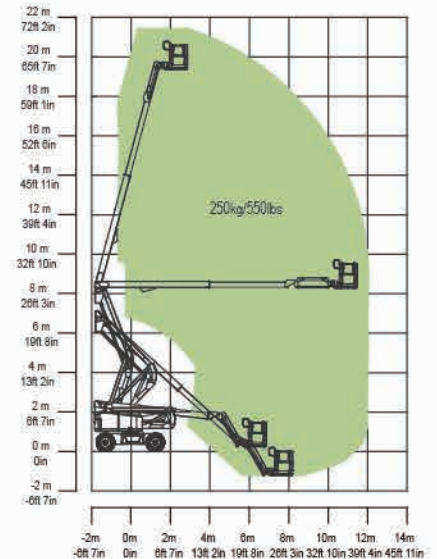
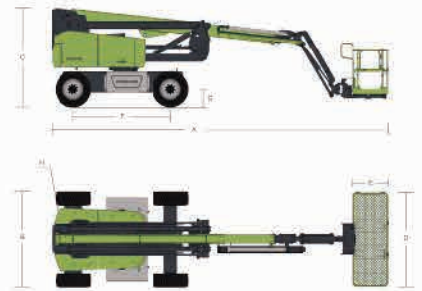

Range of Motion ZA20JE/ZA20JERT-Li

ZOOMLION ARTICULATING BOOM LIFTS

ZA20J

Comply with CE/ANSI/CSA Standard

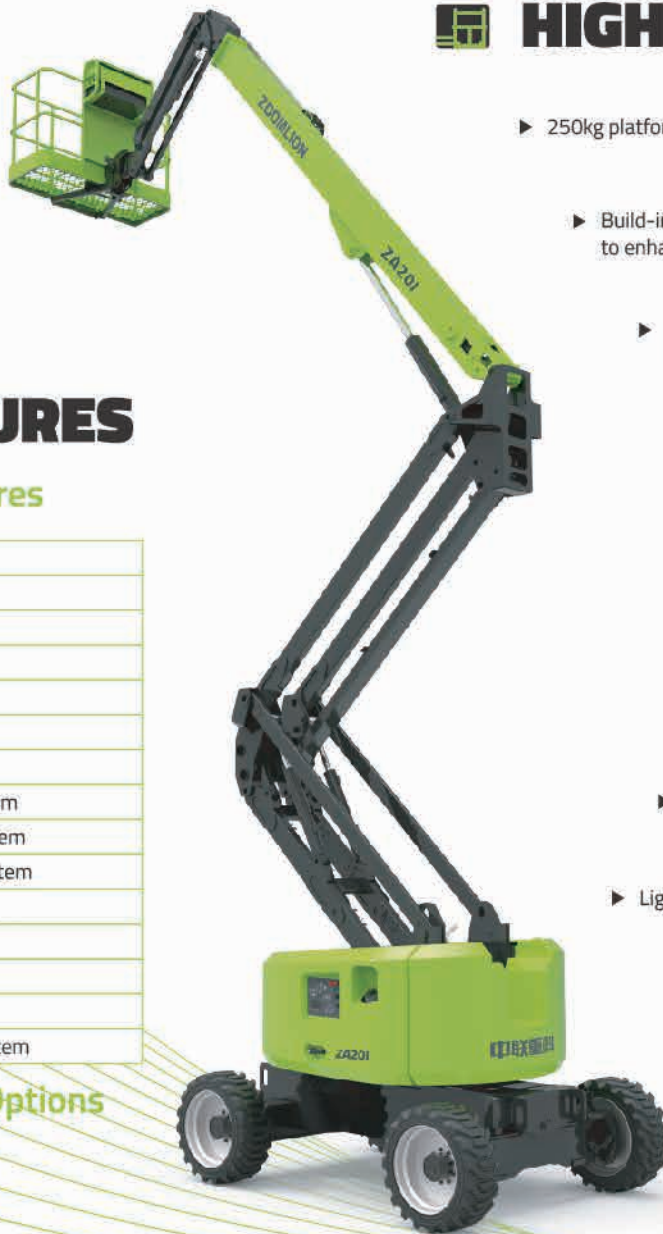

FEATURES

Standard Features

Horn
All motion alarm
Proportional control
Self-closing entry gate
Flashing amber beacon
Auto-leveling system
Emergency stop button
Over tilt protection system
Emergency descent system
On-board diagnostic system
Oscillating axle
4.3' LED display
Load sensing system
Swing-out engine tray
Secondary Guarding System

Accessories & Options

- ▶ Platform work lights
- ▶ AC power to platform
- ▶ Air line to platform
- ▶ Engine heater
- ▶ Low-temperature hydraulic oil

HIGHLIGHTS

- ▶ 250kg platform capacity for higher efficiency
- ▶ Build-in multiple pressure control leveling system to enhance stability
- ▶ Precise load sensing system to improve overload safety operations
- ▶ Integrated with rotary reducer to enhance rotation stability
- ▶ Hostile Kits available for dusty working environment
- ▶ Deadweight Lowering System for smooth operation and energy efficiency
- ▶ Platform fast lifting function provides high-efficient performance without tower boom operation
- ▶ Lightweight design, low energy consumption

ACCESS WITH ZOOMLION GREEN

Phone: 0086(731)-88353690 0086(731)-88250971
E-mail: awm@zoomlion.com

Add: ZOOMLION Wangcheng Industrial Park, Tengfei Road 997, Changsha, Hunan, China
Web: www.en.zoomlion.com

MAIN SPECS OF ARTICULATING BOOM LIFTS

ZA20J

Comply with CE/ANSI/CSA Standard

Model	ZA20J	
	Imperial	Metric
Size		
Work Height	70ft 2in	21.38m
Platform Height	63ft 7in	19.38m
Horizontal Outreach	40ft 4in	12.3m
Up and Over Height	27ft 1in	8.25m
A - Stowed Length	28ft 11in	8.82m
B - Stowed Width	8ft 1in	2.46m
C - Stowed Height	8ft 4in	2.52m
D - Platform Length	8/6ft	2.44/1.83m
E - Platform Width	3ft/2ft 6in	0.91/0.76m
Jib Length	5ft	1.53m
F - Wheelbase	8ft 3in	2.52m
G - Ground Clearance	1ft 5in	0.42m
Performance		
Platform Capacity	550 lb	250kg
Drive Speed	3.79 mph	6.1km/h
Gradeability	45%(24°)	
Axles Oscillation	8in	0.2m
Turning Radius (Inside)	8ft 3in	2.51m
Turning Radius (Outside)	17ft 11in	5.47m
Turntable Swing	360° continuous	
Platform Rotation	±90°	
H-Tail Swing	1ft 4in	0.4m
Max. Wind Speed	28mph	12.5m/s
Power		
Diesel Engine	Kubota V2403 36kW/2600rpm Weichai WP3.2G50E317A 36.8kW/2500rpm	
Fuel Tank Capacity	39.6 (us gal)	150L
Auxiliary Power	12V	
Control Voltage	12V	
Hydraulic System Capacity	42.3 (us gal)	160L
Hydraulic Tank Capacity	19.8 (us gal)	75L
Tire		
Type	33×12/D610 Foam-filled Tires	
Weight		
Gross	22046 lb	10000kg

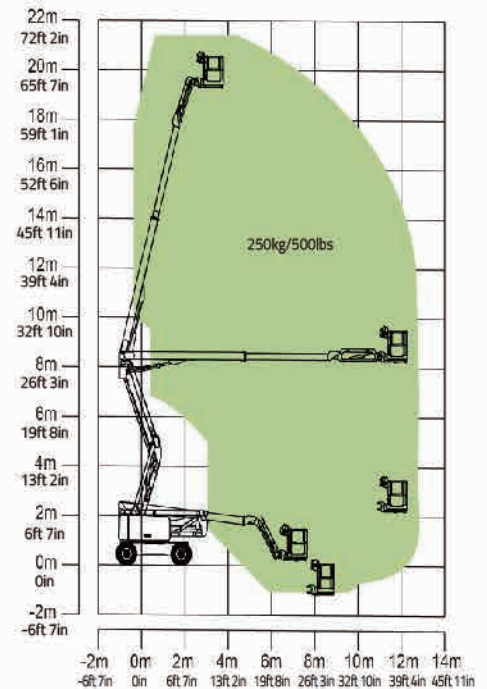
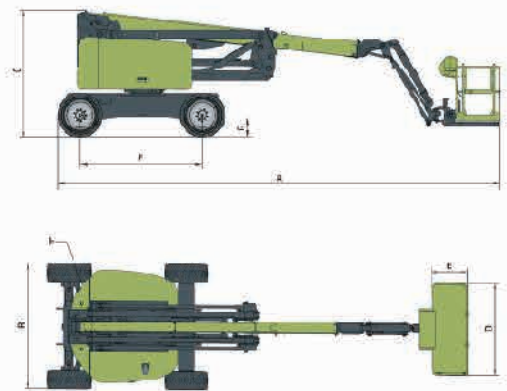

Range of Motion ZA20J

ZOOMLION ARTICULATING BOOM LIFTS

ZA24J

Comply with CE Standard



HIGHLIGHTS



- ▶ 550lb/250kg platform capacity for higher efficiency
- ▶ Build-in multiple pressure control system to enhance stability
- ▶ Precise load sensing system to improve overload safety operations
- ▶ Platform fast lifting function provides high-efficient performance without tower boom operation



FEATURES

Standard Features

Horn
All motion alarm
Proportional control
Self-closing entry gate
Flashing amber beacon
Auto-leveling system
Emergency stop button
Over tilt protection system
Emergency descent system
On-board diagnostic system
Oscillating axle
4.3' LED display
Load sensing system
Swing-out engine tray
Secondary Guarding System

- ▶ Hostile Kits available for dusty working environment
- ▶ Outstanding below ground reach of 5.1m
- ▶ 86ft 11in/26.50m working height

Accessories & Options

- ▶ Platform work lights
- ▶ AC power to platform
- ▶ Air line to platform
- ▶ Engine heater
- ▶ Low-temperature hydraulic oil



ACCESS WITH ZOOMLION GREEN

MAIN SPECS OF ARTICULATING BOOM LIFTS

ZA24J

Comply with CE Standard

Model	ZA24J	
	Imperial	Metric
Size		
Work Height	86ft 11in	26.5m
Platform Height	80ft 5in	24.5m
Horizontal Outreach	62ft	18.9m
Up and Over Height	30ft 11in	9.42m
A - Stowed Length	36ft 11in	11.25m
B - Stowed Width	8ft 2in	2.49m
C - Stowed Height	9ft 10in	3.0m
D - Platform Length	8ft	2.44m
E - Platform Width	2ft 12in	0.91m
Jib Length	6ft	1.83m
F - Wheelbase	10ft	3.05m
G - Ground Clearance	1ft 4in	0.4m
Performance		
Platform Capacity	550 lb	250kg
Drive Speed	3.11 mph	5.0km/h
Gradeability	45%(24°)	45%(24°)
Axes Oscillation	8in	0.2m
Turning Radius (Inside)	10ft 12in	3.35m
Turning Radius (Outside)	21ft 3in	6.48m
Swing	360° continuous	
Platform Rotation	±90°	
H-Tail Swing	3ft 1in	0.94m
Max. Wind Speed	28mph	12.5m/s
Power		
Diesel Engine	Cummins QSF2.8 54kW/2400rpm	
Fuel Tank Capacity	39.6 (us gal)	150L
Auxiliary Power	12V	
Control Voltage	12V	
Hydraulic System Capacity	63.4 (us gal)	240L
Hydraulic Tank Capacity	47.6 (us gal)	180L
Drive	4WD	
Tire		
Type	15-625 Foam-filled Tires	
Weight		
Gross	40344 lb	18300kg

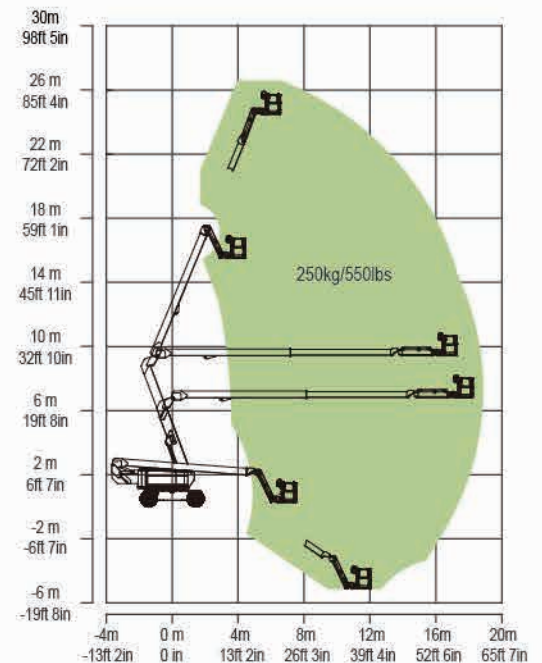
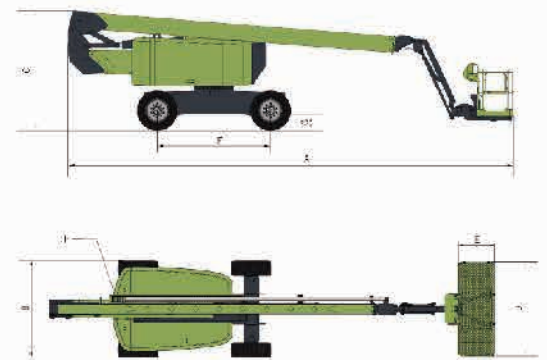

Range of Motion ZA24J

ZOOMLION

ARTICULATING BOOM LIFTS

ZA32J

Comply with CE Standard

FEATURES

Standard Features

Horn
All motion alarm
Proportional control
Self-closing entry gate
Flashing beacon
Auto-leveling system
Emergency stop button
Over tilt protection system
Emergency descent system
On-board diagnostic system
Oscillating axle
4.3' LED display
Load sensing system
Swing-out engine tray
Secondary Guarding System

Accessories & Options

- ▶ Platform work lights
- ▶ AC power to platform
- ▶ Air line to platform
- ▶ Engine heater
- ▶ Low-temperature hydraulic oil
- ▶ AC generator, 110V/50Hz or 220V/50Hz



HIGHLIGHTS

- ▶ Provide heavy lifting of 250kg/550lb load for 28% higher efficiency
- ▶ Build-in multiple pressure control leveling system to enhance stability
- ▶ Precise load sensing system to improve overload safety operations
- ▶ Deadweight Lowering System for smooth operation and energy efficiency
- ▶ Outstanding below ground reach of 5.7m(18ft 8in)

ACCESS WITH ZOOMLION GREEN

Phone: 0086(731)-88353680 0086(731)-88250971
E-mail: awm@zoomlion.com

Add: ZOOMLION Wangcheng Industrial Park, Tengfei Road 997, Changsha, Hunan, China
Web: www.en.zoomlion.com

ARTICULATING BOOM LIFTS

ZA32J

Comply with CE Standard

Model	ZA32J	
	Imperial	Metric
Size		
Work Height	111ft 1in	33.85m
Platform Height	104ft 6in	31.85m
Horizontal Outreach	69ft 5in	21.17m
Up and Over Height	47ft 8in	14.52m
A - Stowed Length	41ft 4in	12.6m
B - Stowed Width	8ft 2in	2.49m
C - Stowed Height	10ft 2in	3.1m
D - Platform Length	8ft	2.44m
E - Platform Width	3ft 12in	0.91m
Jib Length	8ft	2.44m
F - Wheelbase	12ft 6in	3.81m
G - Ground Clearance	1ft 5in	0.42m
Performance		
Platform Capacity	550 lb	250kg
Drive Speed	3.23 mph	5.2km/h
Gradeability	45% (24°)	45% (24°)
Axles Oscillation	8in	0.2m
Turning Radius (Inside)	25ft 3in/10ft 10in	7.7/3.3m
Turning Radius (Outside)	35ft 5in/26ft 11in	10.8/8.2m
Swing	360° continuous	
Platform Rotation	±90°	
H-Tail Swing	0	
Max. Wind Speed	28mph	12.5m/s
Power		
Diesel Engine	Cummins QSF2.8 54kW/2400rpm	
Fuel Tank Capacity	52.8 (us gal)	200L
Auxiliary Power	12V	
Control Voltage	12V	
Hydraulic System Capacity	79.3 (us gal)	300L
Hydraulic Tank Capacity	52.8 (us gal)	200L
Tire		
Type	445/50D710 Foam-filled Tires	
Weight		
Gross	42328 lb	19200kg

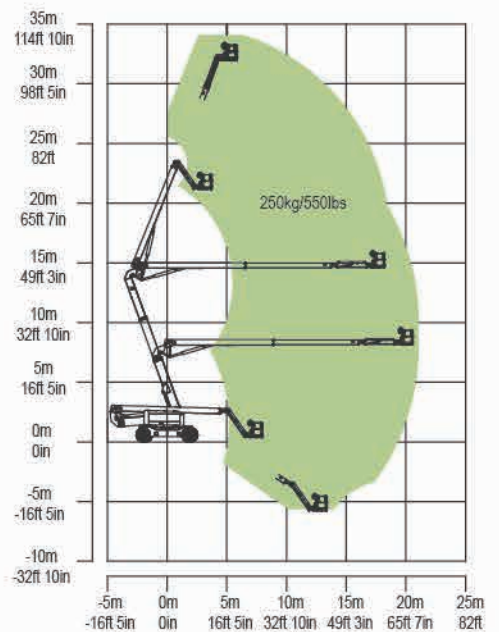
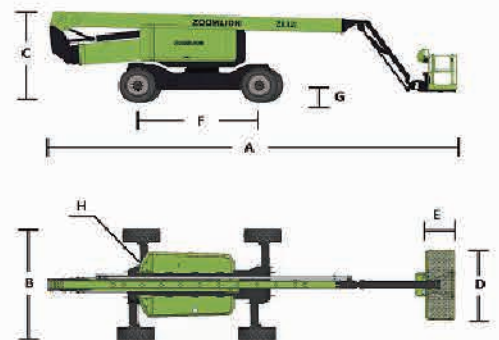

Range of Motion ZA32J