

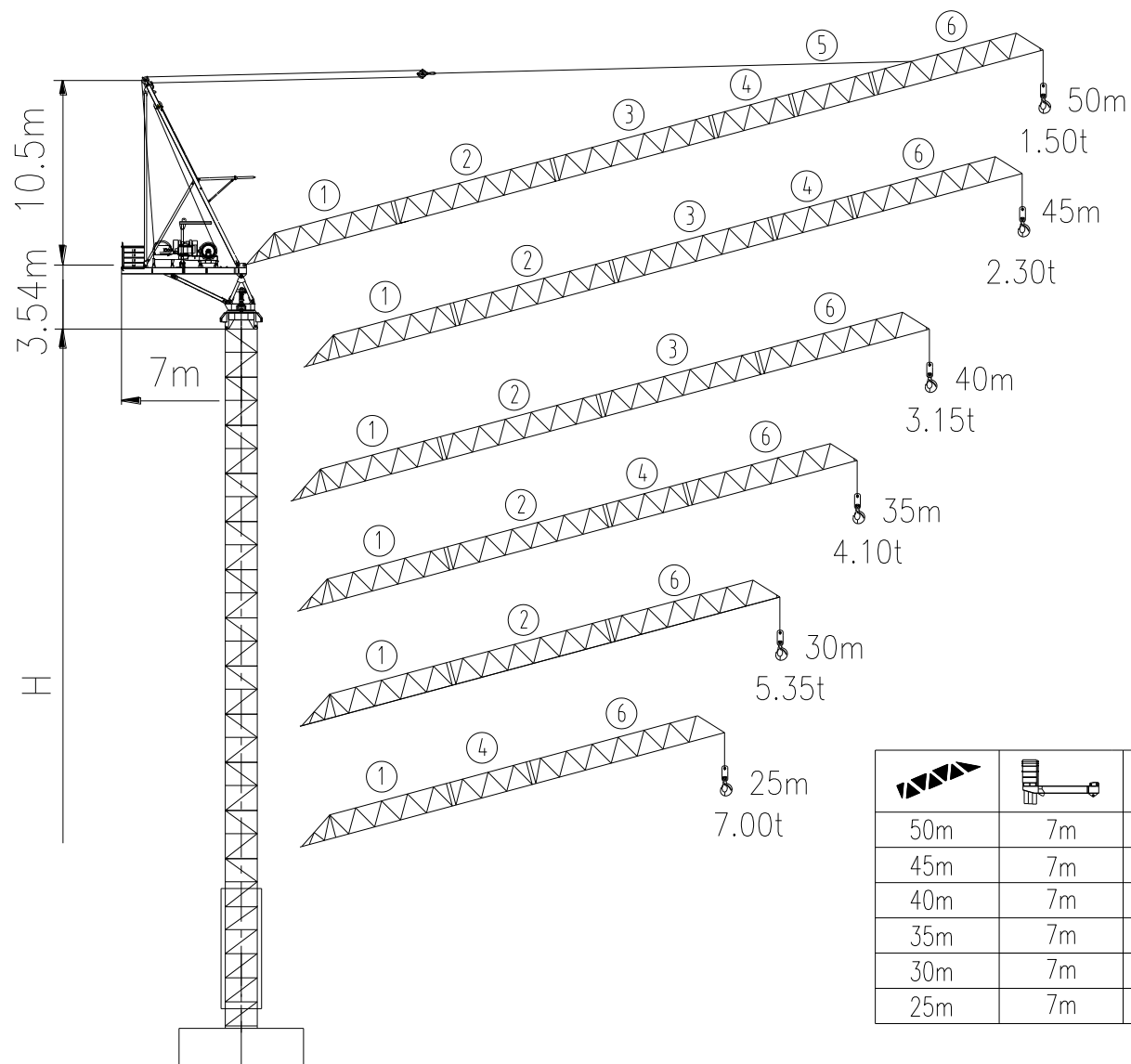



L125-10F/S

L125-10F/S Luffing Jib Tower Crane

Stylebook

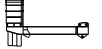

		H	 (kg)	PHZ4100	PHZ1600
50m	7m	H1	15500	3	2
45m	7m	H2	13900	3	1
40m	7m	H3	13900	3	1
35m	7m	H4	13900	3	1
30m	7m	H5	12300	3	0
25m	7m	H6	12300	3	0

塔身 Masts L125-10F

反力 Reactions H(m)

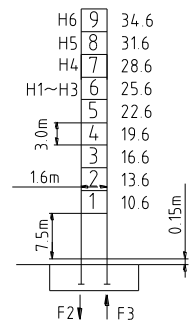

Outrigger	
F2	● 140t ■ 133t
F3	● 108t ■ 106t
	⊕ 38.5t

支腿固定式 Outrigger

H(m)

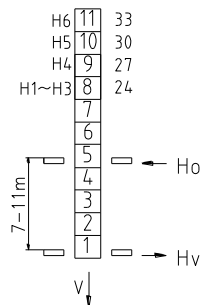

Internal climbing	
Ho	● 414t ■ 39.6t
Hv	● 26.8t ■ 29.5t
V	73.2t

● 工作状态反力 Reactions in service

■ 非工作状态反力 Reactions out of service

⊕ 独立高度、最大起重臂的自重(不含平衡重、吊重)

Weight with max free-standing height, max jib (without counter-weight and load)

内爬式 Internal climbing

* 请联系我们 Please consult us

附着(塔身高度)

Anchorage

超出咨询我们

Consult us if overtop

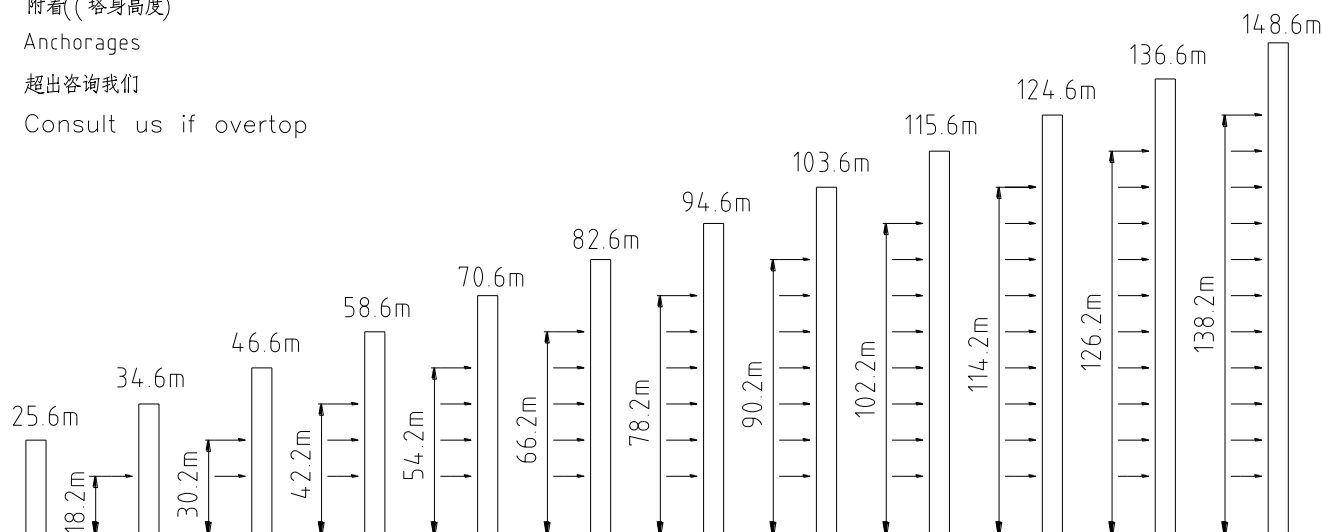

塔身 Masts L125-10S

反力 Reactions H(m)

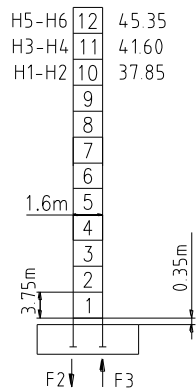

支腿固定式 Outrigger

Outrigger	
F2	● 180t
	■ 232t
F3	● 141t
	■ 198t
⊕	54t

H(m)

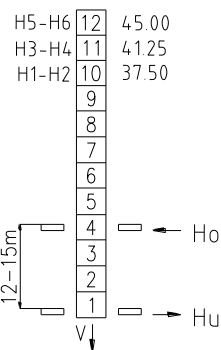

内爬式 Internal climbing

Internal climbing	
Ho	● 26.9t
	■ 50.4t
Hu	● 18.5t
	■ 33.7t
V	87.5t

- 工作状态反力 Reactions in service
- 非工作状态反力 Reactions out of service
- ⊕ 独立高度、最大起重臂的自重(不含平衡重、吊重)
Weight with max free-standing height, max jib (without counter-weight and load)

* 请联系我们 Please consult us

附着((塔身高度)

Anchorage

超出咨询我们

Consult us if overtop

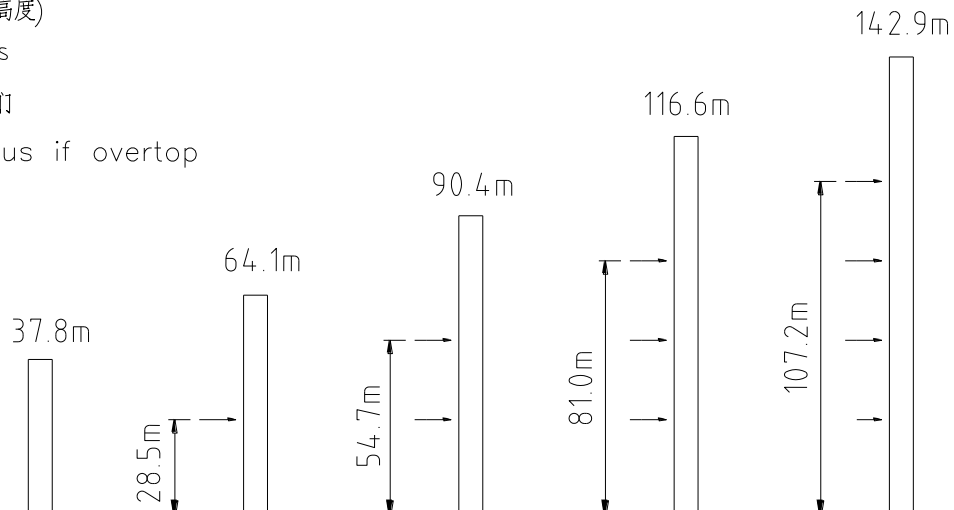



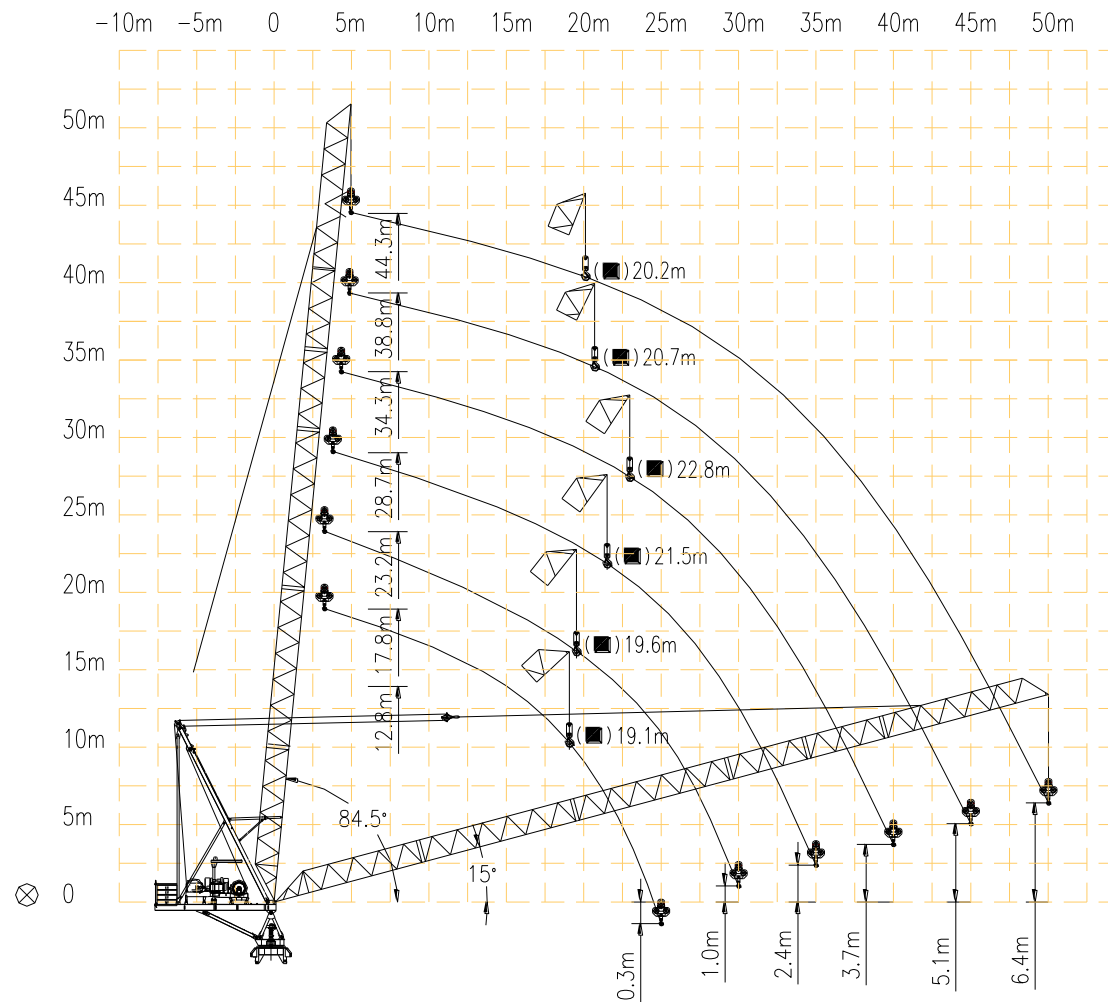





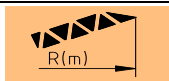







Luffing jib





Minimum radius out of service

Load diagrams





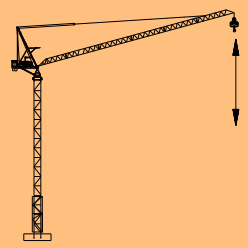
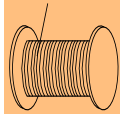
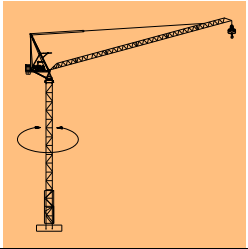
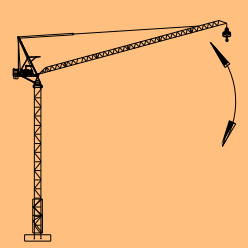

		Max Capacity m/t	20.0	22.5	25.0	27.5	30.0	32.5	35.0	37.5	40.0	42.5	45.0	47.5	50.0
50		4.94~18.92/10.00	9.33	7.89	6.70	5.72	4.91	4.23	3.65	3.15	2.70	2.31	1.97	1.67	1.39
		4.94~23.15/7.50	7.50		6.78	5.81	5.00	4.32	3.73	3.22	2.78	2.38	2.04	1.73	1.45
		4.94~30.02/5.00	5.00					4.40	3.81	3.30	2.85	2.45	2.10	1.79	1.50
45		4.04~19.04/10.00	9.50	8.04	6.87	5.91	5.11	4.43	3.86	3.36	2.92	2.54	2.20		
		4.49~23.59/7.50	7.50		6.95	6.00	5.18	4.51	3.93	3.42	2.98	2.60	2.25		
		4.49~30.75/5.00	5.00					4.59	4.00	3.49	3.05	2.65	2.30		
40		4.04~19.19/10.00	9.59	8.14	6.97	6.02	5.23	4.56	3.98	3.49	3.06				
		4.04~23.75/7.50	7.50		7.05	6.09	5.30	4.62	4.04	3.54	3.10				
		4.04~31.15/5.00	5.00					4.69	4.10	3.60	3.15				
35		3.59~18.95/10.00	9.41	8.01	6.88	5.97	5.20	4.55	4.00						
		3.59~23.53/7.50	7.50		6.96	6.03	5.27	4.61	4.05						
		3.59~31.11/5.00	5.00					4.67	4.10						
30		3.14~18.96/10.00	9.44	8.06	6.96	6.05	5.30								
		3.14~23.75/7.50	7.50		7.02	6.11	5.35								
		3.14~30.00/5.00	5.00												

		Max Capacity m/t	20.0	22.5	25.0
25		4.94~18.90/10.00	9.37	8.03	6.95
		4.94~23.15/7.50	7.50		7.00
		4.94~25.00/5.00	5.00		

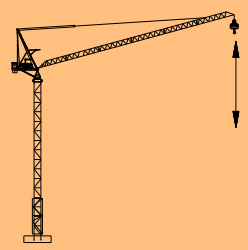
Mechanisms arrangement A

	Hoisting 	Configuration		bd			bd			bd			kW	
				III	IV	V	III	IV	V	III	IV	V		
B	Slewing 	HPW55F1.130B HPW55F2.130B	r/min	0~0.79									2x5.5	Consult us if overtop
			t	5	5	2.5	7.5	7.5	3.75	10	10	5		
	Luffing 	L30FP35	min	3.0(15°~85°)									30	
		380V(± 10%) 50Hz	78 kW											

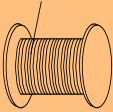
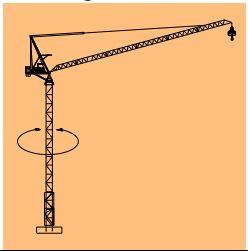
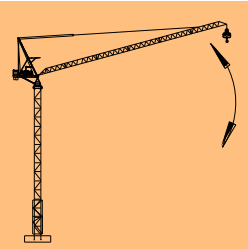
Mechanisms arrangement B

A	 <p>Hoisting</p>	Configuration											kW	
				III	IV	V	III	IV	V	III	IV	V		
	H45FL25-1010D	m/min	45	90	112.5	30	60	75	22.5	45	56	45	1010m \oplus (7 layers)	
		t	5	2.5	1.25	7.5	3.75	1.88	10	5	2.5			
 <p>Slewing</p>	HPW55F1.130B HPW55F2.130B	r/min	0~0.79									2x5.5	Consult us if overtop	
 <p>Luffing</p>	L37FL35-b	min	2.2(15°~85°)									37		
	380V(10%)50Hz	93 kW												

Packing list/ Upper parts

No	Description		Sketch	L(m)	B(m)	H(m)	Weight Per piece(t)	Qty
1		Jib I		10.50	1.33	1.45	1.47	1
2		Jib II		10.43	1.33	1.31	1.01	1
3		Jib III		10.43	1.33	1.29	1.01	1
4		Jib IV		5.26	1.33	1.31	0.47	1
5		Jib V		5.26	1.33	1.29	0.46	1
6		Jib VI		10.42	1.33	1.77	1.20	1
7		Frontal strut (A-frame)		11.92	1.65	0.68	2.23	1
8		Buffer (A-frame)		3.22	1.47	0.31	0.35	1
9		Back strut (A-frame)		10.01	1.39	0.33	0.81	1
10		Slewing assembly		2.17	2.11	2.51	3.60	1

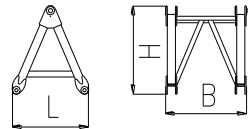
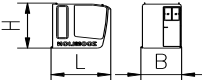
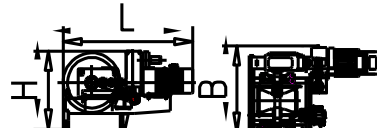
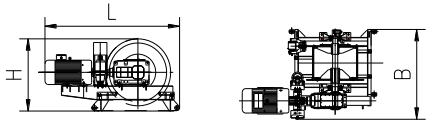
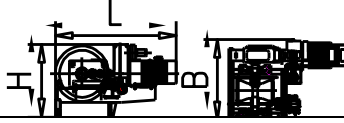
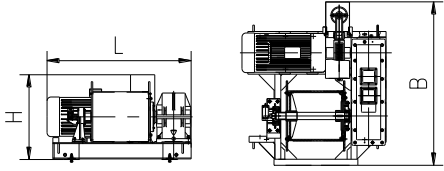
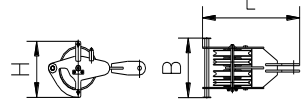
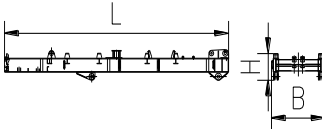
No	Description		Sketch	L(m)	B(m)	H(m)	Weight Per piece(t)	Qty
11		Slewing tower mast		1.56	1.46	1.60	0.66	1
12		Cabin		2.08	1.5	2.23	0.5	1
13A		Luffing mechanism (37kW)		2.76	1.70	1.51	3.05	1
14A		Hoisting mechanism (45W)		2.93	1.93	1.52	3.09	1
13B		Luffing mechanism (30kW)		2.05	1.99	1.22	2.65	1
14B		Hoisting mechanism (37kW)		1.81	2.04	1.04	2.59	1
15		Luffing pulley assembly		1.13	0.4	0.53	0.1	1
16		Counter jib structure		7.3	1.54	0.87	3.21	1

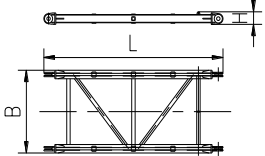
No	Description		Sketch	L(m)	B(m)	H(m)	Weight Per piece(t)	Qty
17		Lower strut of counter jib		3.55	1.51	0.24	0.47	1

Packing list/Bottom parts/L125-10F

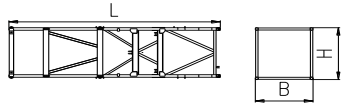
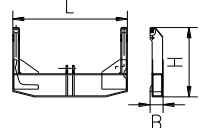
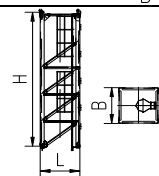
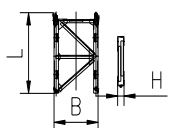
No	Description		Sketch	L(m)	B(m)	H(m)	Weight Per piece(t)	Qty
1		Climbing frame		7.15	2.05	2.05	2.23	1
2		Climbing beam		1.48	0.19	0.77	0.25	1
3		Base tower section		1.6	1.6	7.74	2.6	1
4		Tower section		1.6	1.6	3.24	1.17	6

Packing list/Bottom parts/L125-10S

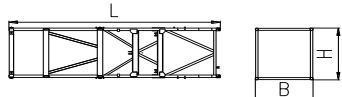
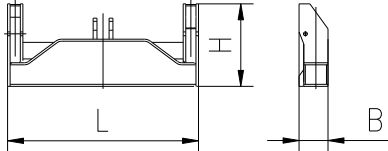
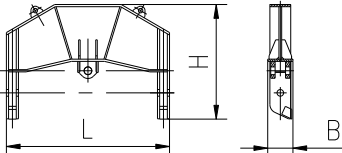
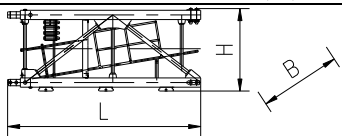
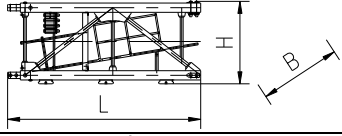
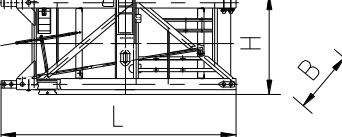
No	Description	Sketch	L(m)	B(m)	H(m)	Weight Per piece(t)	Qty
1	Climbing frame		8.93	2.16	2.45	3.91	1
2	Climbing beam		1.50	0.23	0.65	0.25	1
3	Internal climbing beam		1.49	1.04	0.23	0.35	1
4	Tower section		4.02	1.6	1.69	2.63	9
5	Base tower section		4.02	1.6	1.72	2.63	1
6	Internal base tower section		4.02	1.62	1.69	4.16	1